

# V481 Series

**x86 computers with 8 serial ports, dual LANs, VGA, CompactFlash, USB, audio**



- > Intel Celeron M 1 GHz CPU, 400 MHz FSB
- > 256 MB (CE) or 512 MB (XPe) DDR SDRAM, 256 MB (CE) or 1 GB (XPe) industrial CompactFlash built in
- > 8 software-selectable RS-232/422/485 serial ports
- > Serial port speed from 50 bps to 921.6 Kbps, supporting non-standard baudrates
- > 10/100 Mbps and 10/100/1000 Mbps LANs for network redundancy
- > Supports 2nd CompactFlash socket for storage expansion
- > 2 USB 2.0 hosts that support system bootup
- > LED indicators for system power and storage
- > Designed to withstand 5g's of continuous vibration and 50g shocks
- > Ready-to-run WinCE 5.0 or Windows XP Embedded platform
- > DIN-rail or wall-mount installation
- > Robust, fanless design
- > Wide temperature model available



## Overview

The V481 ready-to-run embedded computers are based on the Intel x86 processor, and come with VGA interface, dual LANs, 8 serial ports, CompactFlash, USB, and audio. The VGA interface was included to make this computer particularly well-suited for industrial applications, such as SCADA and factory automation.

The V481 computers come with 8 software-selectable RS-232/422/485 serial ports built in, making them ideal for connecting a wide range of serial devices. The 10/100 Mbps and 10/100/1000 Mbps LAN ports offer a reliable solution for network redundancy, promising continuous operation for data communication and management. In addition, the second CompactFlash socket makes storage expansion easier, and the USB slots can be used to connect different types of devices, making

the V481 a reliable embedded computer for industrial applications that require VGA and HMI features.

The V481 comes with the Windows CE 5.0 or Windows XP Embedded operating system pre-installed, providing a friendly environment for programmers to develop sophisticated application software. The great software support that Moxa provides makes the programmer's job easier, and makes it possible to develop bug-free code quickly and at a lower cost. In addition, the wide operating temperature model, which works in temperatures ranging from -35 to 75°C, provides users with a great solution for any harsh environment.

## Appearance

### Front View

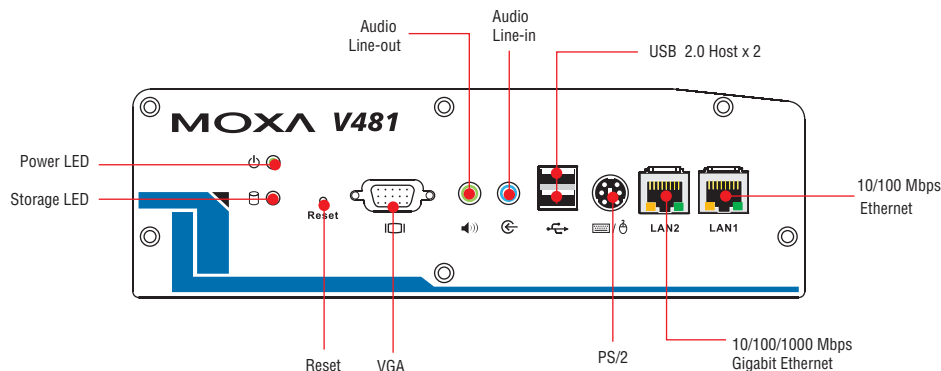

## Rear View

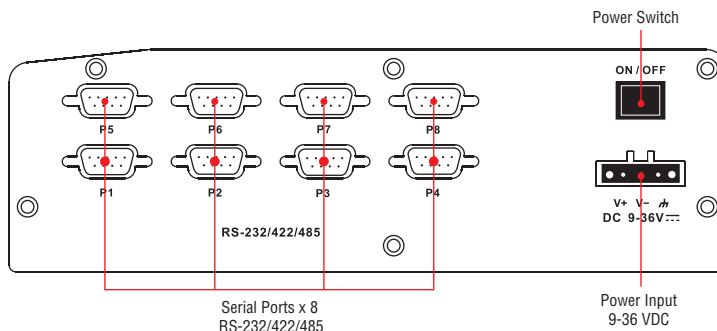

## Hardware Specifications

### Computer

**CPU:** Intel ULV Celeron M 1 GHz processor  
**OS (pre-installed):** Windows CE 5.0 or Windows XP Embedded  
**System Chipset:** Intel 852GM GMCH +ICH4  
**BIOS:** 4 Mbit Flash BIOS, supporting Plug & Play  
**FSB:** 400 MHz  
**System Memory:** 200-pin SO-DIMM socket with built-in 256 MB (CE) or 512 MB (XPe) DDR, supporting DDR200/266 up to 1 GB  
**Expansion Bus:** PC/104 onboard  
**USB:** USB 2.0 compliant hosts x 2, type A connector, supports system boot up

### Storage

**Built-in:** 256 MB (CE) or 1 GB (XPe) industrial CompactFlash card onboard to store OS  
**Storage Expansion:** CompactFlash socket  
**HDD Support:** IDE connector for hard disk expansion

### Other Peripherals

**KB/MS:** 1 PS/2 interface supporting standard PS/2 keyboard and mouse through Y-type cable  
**Audio:** AC97 audio, with line-in/out interface

### Display

**Graphics Controller:** Integrated graphics with built-in Intel 852GM GMCH and Intel extreme Graphics 2 technology  
**Display Memory:** Dynamic video memory for up to 32 MB of system memory  
**Display Interface:** CRT

### Ethernet Interface

**LAN:** 2 independent LAN ports (RJ45)  
 • LAN1: Auto-sensing 10/100 Mbps Ethernet, using integrated MAC and Intel 82562GZ transceiver  
 • LAN2: Auto-sensing 10/100/1000 Mbps Gigabit Ethernet, using Realtek RTL8110SC controller

**Magnetic Isolation Protection:** 1.5 KV built-in

### Serial Interface

**Serial Standards:** 8 RS-232/422/485 ports, software selectable (DB9 male)

**ESD protection:** 15 KV for all signals

### Serial Communication Parameters

**Data Bits:** 5, 6, 7, 8

**Stop Bits:** 1, 1.5, 2

**Parity:** None, Even, Odd, Space, Mark

**Flow Control:** RTS/CTS, XON/XOFF, ADDC® (automatic data direction control) for RS-485

**Baudrate:** 50 bps to 921.6 Kbps (non-standard baudrates supported; see user's manual for details)

### Serial Signals

**RS-232:** TxD, RxD, DTR, DSR, RTS, CTS, DCD, GND

**RS-422:** TxD+, TxD-, RxD+, RxD-, GND

**RS-485-4w:** TxD+, TxD-, RxD+, RxD-, GND

**RS-485-2w:** Data+, Data-, GND

### LEDs

**System:** Power, Storage

**LAN1:** Act/Link and 10/100 Mbps mode (on connector)

**LAN2:** Act/Link and 10/100/1000 Mbps mode (on connector)

### Switches and Buttons

**Power Switch:** on/off

**Reset Button:** For warm reboot

### Physical Characteristics

**Housing:** Aluminum

**Weight:** 2.2 kg

### Dimensions:

Without ears: 225 x 140 x 70 mm (8.86 x 5.51 x 2.76 in)

With ears: 248 X 140 X 70 mm (9.76 X 5.51 X 2.76 in)

**Mounting:** DIN-Rail, wall

### Environmental Limits

#### Operating Temperature:

Standard Models: -10 to 60°C (14 to 140°F)

Wide Temp. Models: -35 to 75°C (-31 to 167°F)

**Operating Humidity:** 5 to 95% RH

#### Storage Temperature:

Standard Models: -20 to 80°C (-4 to 176°F)

Wide Temp. Models: -40 to 85°C (-40 to 185°F)

#### Anti-vibration:

• With CF card: 5 g rms @ IEC-68-2-34, random wave, 5-500 Hz, 1 hr per axis

• With hard disk: 1 g rms @ IEC-68-2-34, random wave, 5-500 Hz, 1hr per axis

#### Anti-Shock:

• With CF card: 50 g @ IEC-68-2-27, half sine wave, 11 ms

• With hard disk: 20 g @ IEC-68-2-27, half sine wave, 11 ms

### Power Requirements

**Input Voltage:** 9 to 36 VDC

**Power Consumption:** 24 W

• 650 mA @ 36 VDC

• 1000 mA @ 24 VDC

• 2750 mA @ 9 VDC

### Regulatory Approvals

**EMC:** CE (EN55022 Class A, EN61000-3-2 Class A, EN61000-3-3, EN55024), FCC (Part 15 Subpart B, CISPR 22 Class A), CCC (GB9254, GB 17625.1)

**Safety:** UL/cUL (UL60950-1, CSA C22.2 No. 60950-1-03), LVD (EN60950-1), CCC (GB4943)

**Green Product:** RoHS, CRoHS WEEE

### Reliability

**Alert Tools:** Built-in buzzer and RTC (real-time clock) with battery backup

**Automatic Reboot Trigger:** Built-in WDT (watchdog timer) supporting 1-255 level time interval system reset, software programmable

## Warranty

**Warranty Period:** 3 years

**Details:** See [www.moxa.com/warranty](http://www.moxa.com/warranty)

## Software Specifications

### Windows Embedded CE 5.0

**System Utilities:** Windows command shell, telnet, ftp

**File System:** FAT (on-board flash)

**Protocol Stack:** TCP, UDP, IPv4, SNMP V2, ICMP, IGMP, ARP, HTTP, CHAP, PAP, SSL, DHCP, SNTP, SMTP, Telnet, FTP, PPP

**Telnet Server:** Allows remote administration through a standard telnet client.

**FTP Server:** Used for transferring files to and from remote computer systems over a network.

**Web Server (httpd):** Includes ASP, ISAPI Secure Socket Layer support, SSL 2, SSL 3, and Transport Layer Security (TLS/SSL 3.1) public key-based protocols, and Web Administration ISAPI Extensions.

**Dial-up Networking Service:** RAS client API and PPP, supporting Extensible Authentication Protocol (EAP) and RAS scripting.

**Application Development Software:**

- Moxa WinCE 5.0 SDK
- C Libraries and Run-times
- Component Services (COM and DCOM)
- Microsoft® .NET Compact Framework 2.0 SP2
- XML, including DOM, XQL, XPATH, XSLT, SAX, SAX2
- SOAP Toolkit, Winsock 2.2, SQL Mobile

### Dimensions (unit = mm)

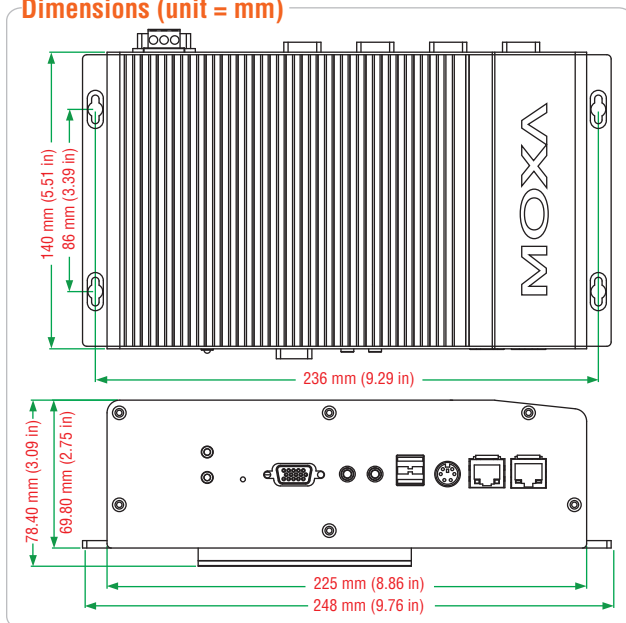

**Note:** The Hardware Specifications apply to the embedded computer unit itself, but not to accessories. In particular, the wide temperature specification does not apply to accessories such as the power adaptor and cables.

### Windows XP Embedded

**System Utilities:** Windows command shell, Telnet, ftp, Wireless Zero Configuration

**File System:** NTFS

**Protocol Stack:** DHCP, IPv4, DNS, IPsec, HTTP, TCP, UDP, ICMP, IGMP, ARP, TAPI, TSP, SNMP V2, NTP, ICS, PPP, CHAP, EAP, SNTP, Telnet, SNTP, FTP, SMTP, PPPoE, PPTP, NetBIOS

**Telnet Server:** Allows users to connect to Telnet servers from remote computers.

**IIS Web Server:** Allows you to create and manage Web sites.

**Terminal Server:** Microsoft Terminal Server client application (mstsc.exe).

**COM+ Services:** The next evolution of Microsoft Component Object Model (COM) and Microsoft Transaction Server (MTS).

**Computer Browser Service:** Computer browsing functionality exposed by Windows through Microsoft Networking. Allows a client machine to browse its network neighborhood for available computers, exposing file and print sharing services.

**Disk Management Services:** Support for disk and volume management operations. The component implements a Component Object Model (COM) interface that can be used to query and configure disks and volumes, both basic and dynamic. The component also monitors disk arrivals and removals and other changes in the storage subsystem.

**Remote Registry Service:** Enables remote users to modify registry settings on this computer.

**Application Development Software:**

- Microsoft .Net Framework 2.0 with service pack 2 (CLR and the .NET Framework class library)
- Active Directory Service Interface (ADSI) Core
- Active Template Library (ATL), ASP.NET 2.0
- Certificate Request Client & Certificate Autoenrollment (CLR and the .NET Framework class library)
- COM APIs
- Common Control Libraries
- Common File Dialogs
- Direct3D, DirectPlay, DirectShow and Direct show filters
- Distributed Transaction Coordinator (MSDTC)
- Enhanced Write Filter (redirects disk write operations to volatile (RAM) or non-volatile (disk) storage)
- Event Log, Internet Explorer
- Mapi32 Libraries
- Message Queuing (MSMQ) Core
- Microsoft Visual C++ Run Time Libraries
- Power Management dynamic-link library
- Registry Editor
- RPC
- Smart Card Cryptographic Service Providers
- USB 2.0 core drivers compliant with USB .95 or 1.0
- Windows API, Media Player 10, Script Engines, and WMI

## Ordering Information

### Available Models

**V481-CE:** x86 embedded computer with VGA, dual LANs, 8 serial ports, CompactFlash, USB, audio, WinCE 5.0, -10 to 60°C operating temperature

**V481-XPE:** x86 embedded computer with VGA, dual LANs, 8 serial ports, CompactFlash, USB, audio, Win XPE, -10 to 60°C operating temperature

**V481-T-CE:** x86 embedded computer with VGA, dual LANs, 8 serial ports, Compact Flash, USB, audio, WinCE 5.0, -35 to 75°C operating temperature

**V481-T-XPE:** x86 embedded computer with VGA, dual LANs, 8 serial ports, CompactFlash, USB, audio, Win XPE, -35 to 75°C operating temperature

### Package Checklist

- V481 embedded computer
- Ethernet cable: RJ45 to RJ45 cross-over cable, 100 cm
- DIN-rail Mounting Kit
- PS2 to KB/MS Y-type Cable
- Document and Software CD or DVD
- Quick Installation Guide (printed)
- Warranty Card