

MGate 5111 Series Quick Installation Guide

Version 1.2, January 2021

Technical Support Contact Information
www.moxa.com/support

MOXA®

© 2021 Moxa Inc. All rights reserved.

P/N: 1802051110012



Overview

The MGate 5111 is an industrial Ethernet gateway for Modbus RTU/ASCII/TCP, PROFINET and EtherNet/IP to PROFIBUS slave network communications.

Package Checklist

Before installing the MGate 5111, verify that the package contains the following items:

- MGate 5111 gateway
- Quick installation guide (printed)
- Warranty card

Please notify your sales representative if any of the above items is missing or damaged.

Optional Accessories (can be purchased separately)

- Mini DB9F-to-TB: DB9-female-to-terminal-block connector
- WK-51-01: Wall-mounting kit, 51 mm wide

Hardware Introduction

Dimensions

Unit = mm (inch)

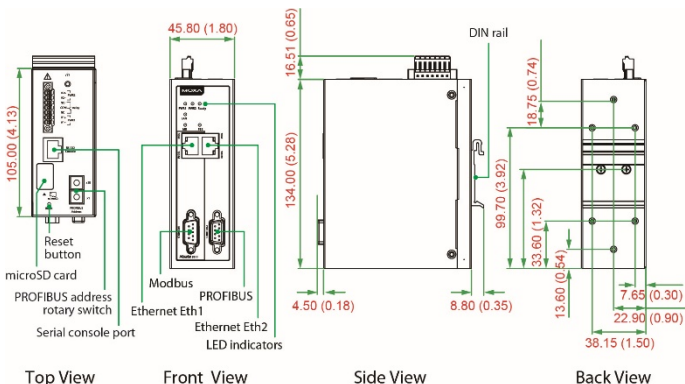

LED Indicators

LED	Color	Description
PWR 1,	Green	Power is on
PWR 2	Off	Power is off
Ready	Green	Steady on: Power is on, and the unit is functioning normally Blinking: The unit is responding to the software's Locate function
	Red	Steady on: Power is on, and the unit is booting up Blinking: Indicates an IP conflict, or the DHCP or BOOTP server is not responding properly Flashing quickly: the microSD card failed
LAN	Green (Flashing only)	The Ethernet port is receiving or transmitting data Modbus TCP Client: Modbus communication in progress Modbus TCP Server: Modbus communication in progress EtherNet/IP Adapter: EtherNet/IP communication is exchanging data PROFINET IO Device: PROFINET communication is exchanging data
	Red (Flashing only)	A communication error occurred Modbus TCP Client: 1. Received an exception code or framing error (parity error, checksum error) 2. Command timeout (slave device is not responding) 3. TCP connection timeout Modbus TCP Server: 1. Received an invalid function code or framing error (parity error, checksum error) 2. Accessed invalid register address or coil address EtherNet/IP Adapter: The connection was refused due to incorrect configuration
	Off	No communication
MB*	Green (Flashing only)	Modbus is receiving or transmitting data
	Red (Flashing only)	A communication error occurred Master Mode: 1. Received an exception code or framing error (parity error, checksum error) 2. Command timeout (the slave device is not responding) Slave Mode: 1. Received an invalid function code or framing error (parity error, checksum error) 2. Accessed invalid register address or coil address
	Off	No communication

LED	Color	Description
PBS	Green (Flashing only)	PROFIBUS is receiving or transmitting data
	Red (Steady)	Error in the configuration or parameter data.
	Off	PROFIBUS offline or Slave ID is wrong.
Eth1, Eth2	Green	Indicates an 100 Mbps Ethernet connection
	Amber	Indicates a 10 Mbps Ethernet connection
	Off	The Ethernet cable is disconnected

*Only indicates serial communication status; for Modbus TCP status, please refer to LAN LED indicator.

Reset Button

Restore the MGate to factory default settings by using a pointed object (such as a straightened paper clip) to hold the reset button down until the Ready LED stops blinking (approximately five seconds).

Pull-Up, Pull-Down, and Terminator for RS-485 (Modbus)

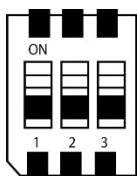

On the MGate 5111's left side panel, you will find DIP switches to adjust each serial port's pull-up resistor, pull-down resistor, and terminator.

SW	MODBUS		
	1	2	3
	Pull-up resistor	Pull-down resistor	Terminator
ON	1 K Ω	1 K Ω	120 Ω
OFF	150 K Ω (default)	150 K Ω (default)	- (default)

Rotary Switch

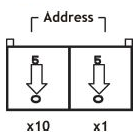

Before communicating, you must assign a slave ID to the PROFIBUS slave. If you would like to assign an address between 0 to 99, you need to change the rotary switch to the desired address. If you would like to assign an address which is over 99, you must set it via web console.

Hardware Installation Procedure

1. Connect the power adapter. Connect the 12-48 VDC power line or DIN-rail power supply to the MGate 5111's terminal block. Make sure the adapter is connected to an earthed socket.
2. Use a PROFIBUS cable to connect the MGate to a PROFIBUS PLC or other PROFIBUS master.
3. Use an Ethernet cable to connect the MGate to the Modbus TCP client, Modbus TCP server device, PROFINET IO controller, or EtherNet/IP scanner device.
4. The MGate 5111 is designed to be attached to a DIN rail or mounted on a wall. For DIN-rail mounting, push down the spring and properly attach it to the DIN rail until it "snaps" into place. For wall mounting, install the wall-mount kit (optional) first and then screw the device onto the wall.

Wall or Cabinet Mounting

Two metal plates are provided for mounting the unit on a wall or inside a cabinet. Attach the plates to the unit's rear panel with screws. With the plates attached, use screws to mount the unit on a wall. The heads of the screws should be 5 to 7 mm in diameter, the shafts should be 3 to 4 mm in diameter, and the length of the screws should be more than 10.5 mm.

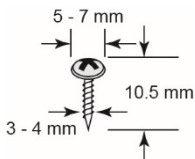

For each screw, the head should be 6 mm or less in diameter, and the shaft should be 3.5 mm or less in diameter.

The following figure illustrates the two mounting options:

Wall-Mount Installation

DIN-Rail Installation

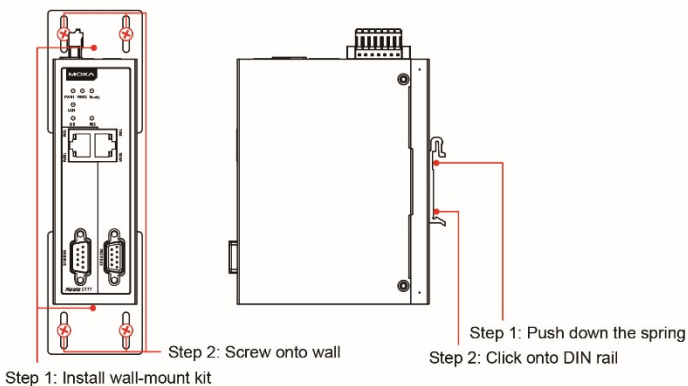

Software Installation Information

Please download the user's manual and DSU (Device Search Utility) from Moxa's website: www.moxa.com. Please refer to the User's Manual for additional details on using the Device Search Utility.

The MGate 5111 also supports login via a web browser.

Default IP address: **192.168.127.254**

Default account: **admin**

Default password: **moxa**

Pin Assignments

Ethernet Port (RJ45)

Pin	Signal
1	Tx+
2	Tx-
3	Rx+
6	Rx-

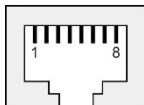

Modbus Serial Port (Male DB9)

Pin	RS-232	RS-422/ RS-485 (4W)	RS-485 (2W)
1	DCD	TxD-(A)	-
2	RXD	TxD+(B)	-
3	TXD	RxD+(B)	Data+(B)
4	DTR	RxD-(A)	Data-(A)
5*	GND	GND	GND
6	DSR	-	-
7	RTS	-	-
8	CTS	-	-
9	-	-	-

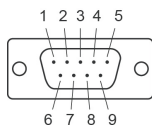

*Signal ground

PROFIBUS Serial Port (Female DB9)

Pin	Signal
1	-
2	-
3	PROFIBUS D+
4	RTS
5	Signal common
6	5V
7	-
8	PROFIBUS D-
9	-

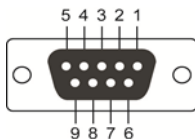

Console Port (RS-232)

The MGate 5111 Series can use an RJ45 serial port to connect to a PC to configure the device.

Pin	Signal
1	DSR
2	RTS
3	GND
4	TXD
5	RXD
6	DCD
7	CTS
8	DTR

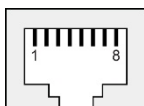

Power Input and Relay Output Pinouts

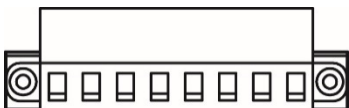

	V2+	V2-				V1+	V1-
Shielded Ground	DC Power Input 2	DC Power Input 2	N.O.	Common	N.C.	DC Power Input 1	DC Power Input 1

Specifications

Power Input	12 to 48 VDC
Power Consumption (Input Rating)	12 to 48 VDC, 416 mA (max.)
Operating Temperature	Standard Models: 0 to 60°C (32 to 140°F) Wide Temp. Models: -40 to 75°C (-40 to 167°F)
Storage Temperature	-40 to 85°C (-40 to 185°F)

ATEX and IECEx Information



1. DEMKO Certificate number: 17 ATEX 1848X
IECEx Certificate number: IECEx UL 17.0019X
2. Ambient Temperature Range:
0°C to 60°C (for models without suffix -T)
-40°C to 75°C (for models with suffix -T only)
3. Certification String: Ex nA nC IIC T4 Gc
4. Standards Covered: EN 60079-0:2012+A11:2013/IEC 60079-0 6th Ed. AND EN 60079-15:2010/IEC 60079-15 4th Ed.
5. The conditions of safe use:
 - a. Ethernet Communications Devices are intended for mounting in a tool-accessible IP54 enclosure and use in an area of not more than pollution degree 2 as defined by IEC/EN 60664-1.
 - b. Conductors suitable for use in an ambient temperature greater than 86°C must be used for the power supply terminal.
 - c. A 4 mm² conductor must be used when a connection to the external grounding screw is utilized.
 - d. Provisions shall be made, either in the equipment or external to the equipment, to prevent the rated voltage from being exceeded by the transient disturbances of more than 140% of the peak-rated voltage.

When wiring the relay contact (R), digital input (DI), and power inputs (P1/P2), we suggest using AWG (American Wire Gauge) 16-24 as a cable and the corresponding pin-type cable terminals. The connector can withstand a maximum torque of 5 pound-inches. The wire temperature rating should be at least 105°C.



ATTENTION

For installations in hazardous locations (Class 1, Division 2): These devices are to be installed in an enclosure with a tool-removable cover or door, suitable for the environment.

NOTE This equipment is suitable for use in Class 1, Division 2, Groups A, B, C, D or nonhazardous locations only



WARNING

EXPLOSION HAZARD

Do not disconnect the equipment unless the power has been switched off, or the area is known to be nonhazardous.



WARNING

EXPLOSION HAZARD

The substitution of any components may impair suitability for Class 1, Division 2.



WARNING

EXPOSURE TO SOME CHEMICALS MAY DEGRADE THE SEALING PROPERTIES OF MATERIALS USED IN THE FOLLOWING DEVICE:
Sealed Relay Device U21.



WARNING

EXPLOSION HAZARD

Indoor use and Pollution degree 2.



WARNING

EXPLOSION HAZARD

The equipment and label must be wiped by a dry cloth.



WARNING

EXPLOSION HAZARD

The device may only be connected to the supply voltage connections compliant with UL60950, or UL61010-1, or UL61010-2-201 Safety Extra-Low Voltages (SELV).

Moxa Inc.

No. 1111, Heping Rd., Bade Dist., Taoyuan City 334004, Taiwan